

USER MANUAL

STR 650-1000 F+PF

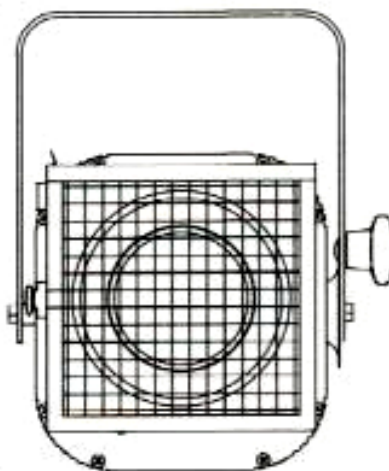

Index

1. General description.....	3
1.1.Characteristics	3
1.2.Technical data	4
1.3.Photometric data.....	5
1.4.Dimensions.....	6
2. Accessories	7
3. Installation	8
3.1.Power supply connection.....	8
3.2.Colour filter installation.....	9
4. Operation.....	10
4.1.Aperture angle adjustment.....	10
5. Maintenance	11
5.1.Regular cleaning.....	11
5.2.Lamp replacement	11
5.3.Lens replacement	11
6. Most common problems.....	13
Statement of compliance	14

1. General description

THEATRE lighting family of Strong is composed of a set of projectors for 650W or 1000W lamps. For this reason they are appropriate in facilities where high-power lighting is required, for instance: theatres, showrooms, etc.

STR 650-1000 F+PF is a lighting projector with pressed fresnel lens.

Moreover, this range includes some accessories which increase the functions of the projectors.

1.1. Characteristics

- Focal adjustment is included by endless screw and back knob.
- Made of aluminium profiles and iron plate. Painted with black oven-dried epoxy.
- Metal filter holder and safety grille are provided with the spotlight.
- Lamp not included.
- STR 650-1000 F+PF reference is 21000002.

1.2. Technical data

<i>Power supply</i>	Single-phase 230V 50Hz
<i>Lamps</i>	T-12 650W // T-11 1000W
<i>Lamp holder</i>	Gx9,5
<i>Aperture angle</i>	Minimum: 10° // Maximum: 63°
<i>Lens</i>	Ø150 mm
<i>Aluminium reflector</i>	99,9 quality, Ø100 mm
<i>Power supply cable</i>	3x1,5mm ² 1metro
<i>Maximum projector temperature</i>	160 °C
<i>Minimum distance to objects</i>	2 m (at the light beam)
<i>Maximum room temperature</i>	40 °C
<i>Weight</i>	5,5 Kg.
<i>Dimensions</i>	360x334x276 mm

1.3. Photometric data

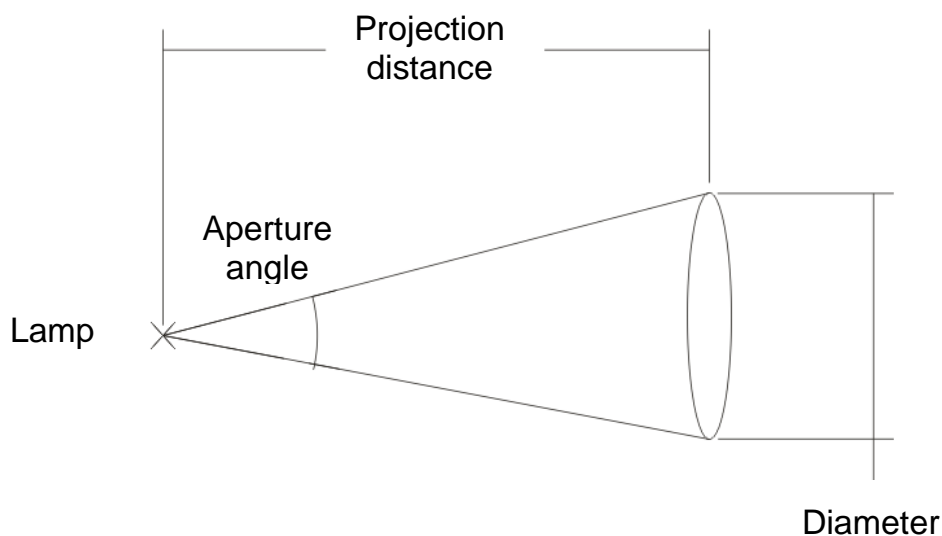

Fig. 1: Light beam

Projection distance [m]	Lamp [W]	Aperture angle [°]	Diameter [cm]	Luminance [lx]	
				Centre	Round
3	650	10 (minimum)	52	5430	1004
		63 (maximum)	260	665	253
	1000	10 (minimum)	52	6155	983
		63 (maximum)	260	942	129
5	650	10 (minimum)	92	1947	282
		63 (maximum)	498	270	67
	1000	10 (minimum)	92	2953	456
		63 (maximum)	498	386	37

1.4. Dimensions

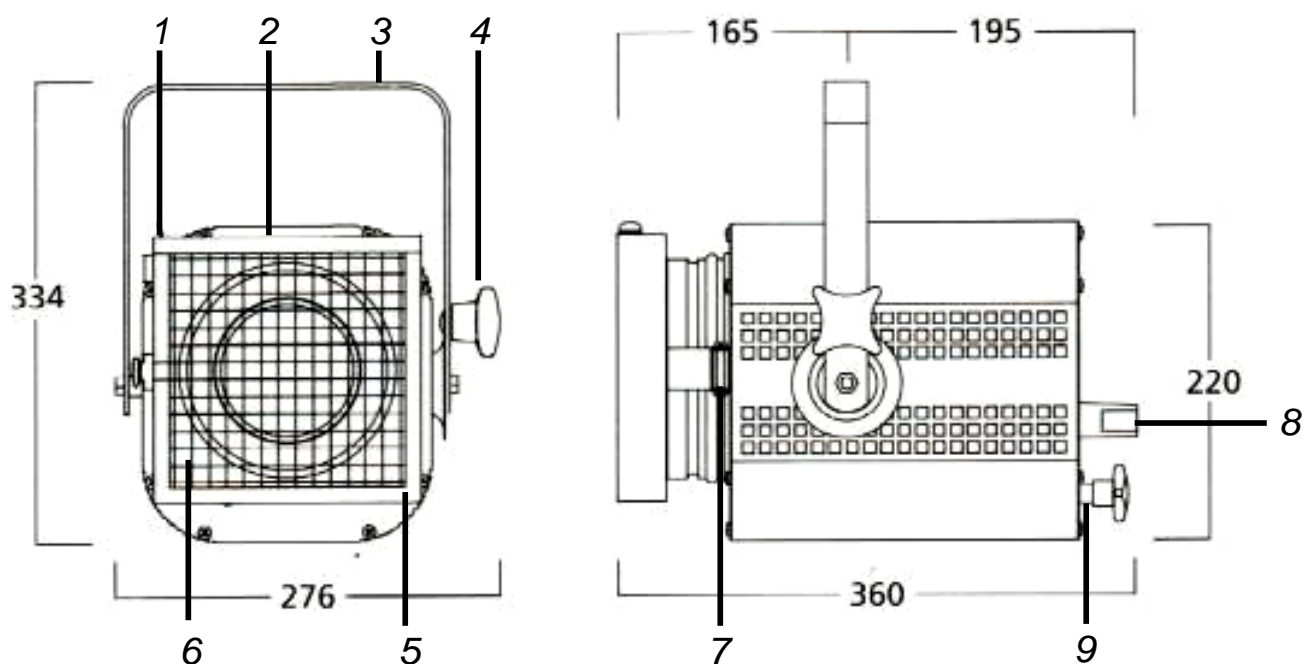

Fig. 2

- | | | |
|---------------------------|-------------------|--------------------------|
| 1. Filter holder fastener | 4. Fastening knob | 7. Front access fastener |
| 2. Filter holder lid | 5. Filter holder | 8. Orienting handle |
| 3. Handle | 6. Safety grille | 9. Focal adjustment nut |

2. Accessories

The accessory range consists of the following products:

- STR 650-1000 V:

Barndoor

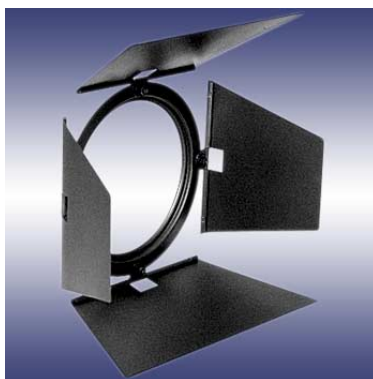

- STR 650-1000 PF:

Filter holder

Dimensions 180x185 mm. Weight: 0,15 Kg.

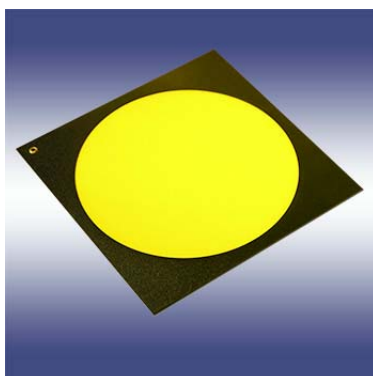

3. Installation

ATTENTION: Before touching the spotlight surface, be sure that it has not been working recently due to the high temperatures of the projector while working because you risk burning yourself. For the same reason, fix the projector away from inflammable surfaces.

First of all, you must be sure that the distance between the projector and the closest object in the light beam should be greater than 2 meters. Otherwise, the object could reach high temperatures which could damage it. It is also recommended placing the projector at 0,2 meters away from any object around it. As well, do not put the unit closed to objects which could emit heat such as heaters and radiators.

The unit is not prepared for working in wet environments (relative humidity greater than 90%). So it can not work under raining conditions.

It must be positioned for not interfering with its proper ventilation.

This projector is equipped with a handle (see 3 at figure 2) to allow to fast it at tube structures and surfaces.

The projector handle can be turned and braked by a knob that allows the proper orientation of the device.

The spotlight must be fixed at a point completely stable and capable of supporting the weight of the equipment (5,5 kg) via the handle, attaching it to this point with the anchor holes. Always use M12 steel screws to set the spotlight.

Once the projector is hanging, vertical inclination can be adjusted by the lateral fastening knob (see 4 in figure 2). Unscrew it to orientate the projector and screw it when you consider that the light beam is correct.

3.1. Power supply connection

During handling and installation of the unit disconnect it from the current.

The spotlight is power supplied when connecting the supply hose to a 230-volt 50-hertz single phase mains with ground. Before connecting the spotlight you must be sure that the voltage supplied is correct.

3.2. Colour filter installation

WARNING: Use colour filters suitable for the temperatures that can reach this lighting projector.

This projector incorporates a holder for colour filters (see 5 in figure 2).

To install a filter, move the filter holder fastener (see 1 in figure 2) by pushing it laterally. Simultaneously rotate 180° the filter holder lid (see 2 in figure 2). Then insert the colour filter in front of the safety grille so that it is placed between the inner grooves.

Finally, proceed closing the filter holder lid in the same way as for the opening.

4. Operation

The projector can be positioned manually varying the inclination. To do this, loosen the fastening knob (see 4 in figure 2) and position it by holding the back plastic handle (see 8 in figure 2).

Be careful not to touch the metal parts because the focus can reach high temperatures.

To fix it again, turn the fastening knob clockwise until fixed it.

4.1. Aperture angle adjustment

The spotlight angle, and consequently the diameter of the light beam can be changed by turning to right and left the focal adjustment nut (see 9 in figure 2).

5. Maintenance

WARNING: Before touching the projector surface make sure that it has not been on recently because it can operate at high temperatures with a risk of burns.

5.1. Regular cleaning

To prevent the growth of dust and dirt which may impair the proper operation of the equipment, it should be cleaned regularly.

For cleaning it, use a soft, slightly and damp cloth (if the equipment is very dirty, apply a little liquid detergent to the cloth).

WARNING: Do not use solvents or products containing alcohol. Make sure that no liquid get inside the equipment.

The lens cleaning must be made with a soft cloth. Water may be used but dry it with a dry cloth to remove all traces of water and dust.

5.2. Lamp replacement

Before proceeding to change the lamp, make sure that the spotlight has not been running recently because it could be hot; if so let it cool for a few minutes.

Lamp replacement begins by turning anticlockwise the focal adjustment nut (see 9 in figure 2) till reach its maximum position. Then open the front access fastener (see 7 in figure 2) and the lamp can be seen inside the projector.

Carefully remove the lamp from the socket, holding it by the plastic part.

WARNING: Do not touch the glass of the lamp because it could affect the service life of the product. If during the installation you touch the lamp glass, wipe with a cloth moistened with alcohol.

When you remove the lamp replace with a new one of the same characteristics (Gx9.5 lamp holder).

Then, reinsert, first the pins, the lamp into the socket by pushing.

Make sure the lamp is properly held. Finally, close the projector front access and the front access fastener (see 7 in figure 2).

Connect the spotlight and check that the lamp is functioning properly.

5.3. Lens replacement

Before proceeding to change the lens, make sure that the projector has not been running recently because it could be hot; if so let it cool for a few minutes.

To change the lens, open the front access fastener (see 7 in figure 2). The lens installed is at your right. An iron ring is placed around the lens. Remove it with the help of a tool to pry it open.

WARNING: The ring holds the lens, be careful not to fall it down.

Tilt the projector and remove the lens, you can press it by the outside to help it out. Insert the new lens. To improve the quality of the light beam be sure of its cleanness.

Finally reinsert the steel ring for holding the lens correctly. Close the front part of the projector and fasten it (see 7 in figure 2).

Verify that the light beam of the new lens is correct.

6. Most common problems

Problem	Usual Cause	Solution
Unit does not start	No current reaching the unit	Check mains connections
	Lamp does not work	Replace the lamp following the instructions of <i>Maintenance</i>

If the problem persists despite these measures, please contact to FRESNEL's Technical Service Department.

Tel: (+34) 93 274 54 28

Tel: (+34) 93 360 02 30

Fax: (+34) 93 274 47 47



If you want to do without this product, do not mix it with the ordinary waste. There are specific methods and systems for dividing electronic and electromagnetic used products that are described in 2002/96/EC directive, which is in force in the European Community countries.

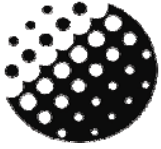

FRESNEL S.A.

STATEMENT OF COMPLIANCE

DC-01

DATE: 01/01/12

We declare that the product:

Mark:

STRONG

Models:

STR 650-1000 F+PF

Year of construction:

2012

Conforms to the following EC directives:

2006/95/EC: In relation to the safety requirements for material intended for use within specific voltage limits.

2004/108/EC: In relation to the electromagnetic compatibility of equipment, systems and installations.

Sole administrator

Ángel Torrecillas Redón

Barcelona, January 1st of 2012

Fresnel S.A.

C/ Potosí 40
08030 Barcelona
Spain
Tel: +34 93 360 02 30
Fax: +34 93 274 47 47
strong@strong.es
<http://www.strong.es>